

大梁加工要領図

工事名：SAMPLE2 (小屋物)

承認	チェック	担当
----	------	----

発注者：

株式会社 カルテック

H-500x200x10x16 10台
SS400 (L=材長)

部品	部位	材長	台	通り	工区/台
GM2	<RG3-X2Y0/1>	7129	1	R階 [X2, Y2-X2, Y0]	
GM2	<RG3-X3Y0/1>	7129	1	R階 [X3, Y2-X3, Y0]	
GM2	<RG3-X4Y0/1>	7129	1	R階 [X4, Y2-X4, Y0]	
GM4	<RG2-X1Y0/1>	3050	1	R階 [X1, Y0]	
GM4	<RG2-X1*2>	3050	1	R階 [X1, Y2]	
GM4	<RG2-X5Y0/1>	3050	1	R階 [X5, Y0]	
GM4	<RG2-X5*2>	3050	1	R階 [X5, Y2]	
GM5	<RG3-X2Y0/2>	1015	1	R階 [X2, Y2-X2, Y0]	
GM5	<RG3-X3Y0/2>	1015	1	R階 [X3, Y2-X3, Y0]	
GM5	<RG3-X4Y0/2>	1015	1	R階 [X4, Y2-X4, Y0]	

備考

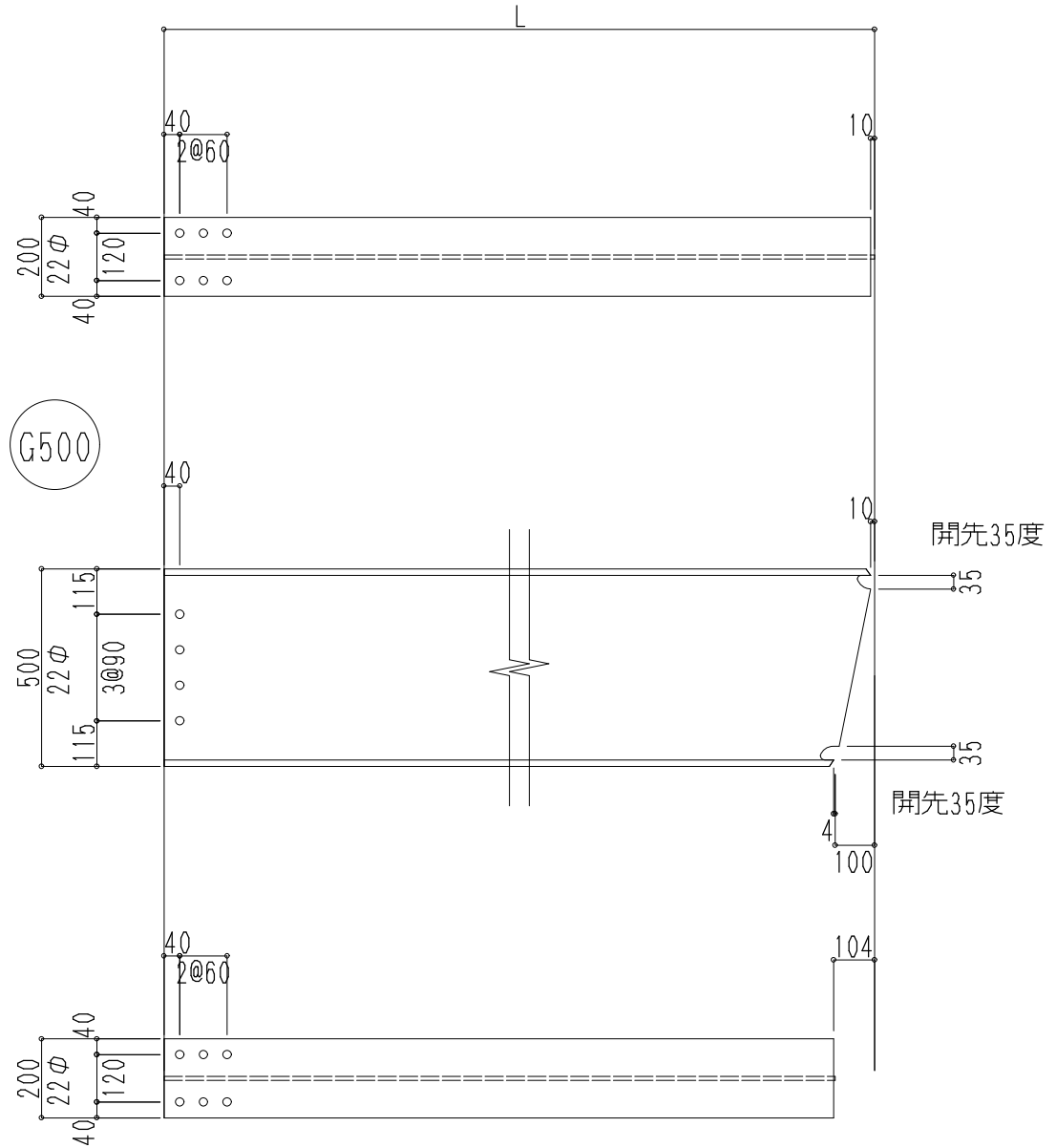

小梁加工要領図

工事名：SAMPLE2 (小屋物)

承認	チェック	担当
----	------	----

発注者：

株式会社 カルテック

H-300x150x6.5x9 SS400 4台 (L=材長)

部品	部位	材長	台	通り	工区/台
BM1	<RB-3>	7640	1	R階 [X0, Y2-X0, Y1]	
BM1	<RB-3>	7640	1	R階 [X0, Y1-X0, Y0]	
BM1	<RB-4>	7640	1	R階 [X6, Y2-X6, Y1]	
BM1	<RB-4>	7640	1	R階 [X6, Y1-X6, Y0]	

備考

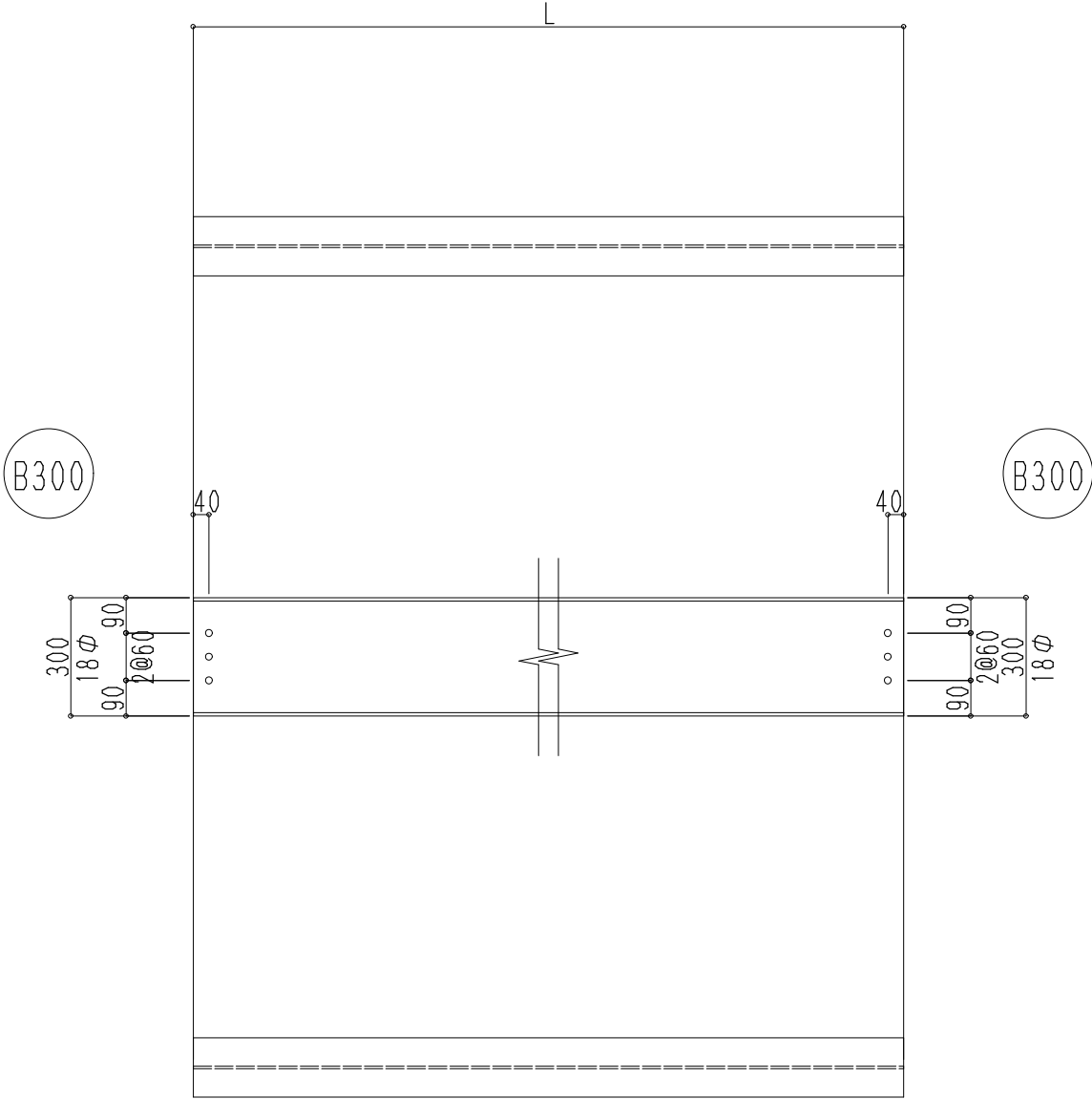

ブラケット加工要領図

工事名 : SAMPLE2 (小屋物)

承認	チェック	担当
----	------	----

発注者 :

株式会社 カルテック

H-200x100x5. 5x8 10台
SS400 (L=材長)

部品	部位	材長	台	通り	工区/台
BKM4	<1MTG2#X1Y0>	850	1	1M階 [X1, Y0]	
BKM4	<1MTG2#X1Y2>	850	1	1M階 [X1, Y2]	
BKM4	<1MTG2#X2Y0>	850	1	1M階 [X2, Y0]	
BKM4	<1MTG2#X2Y2>	850	1	1M階 [X2, Y2]	
BKM4	<1MTG2#X3Y0>	850	1	1M階 [X3, Y0]	
BKM4	<1MTG2#X3Y2>	850	1	1M階 [X3, Y2]	
BKM4	<1MTG2#X4Y0>	850	1	1M階 [X4, Y0]	
BKM4	<1MTG2#X4Y2>	850	1	1M階 [X4, Y2]	
BKM4	<1MTG2#X5Y0>	850	1	1M階 [X5, Y0]	
BKM4	<1MTG2#X5Y2>	850	1	1M階 [X5, Y2]	

備考

